

Dimensión del Flange				
DN	A	B	F	G
1"	108	79	50	25
2"	153	121	50	25
3"	191	152	50	25
4"	229	190	50	25
6"	280	241	152	76
8"	343	298	152	76
10"	407	362	200	100
12"	483	432	200	100

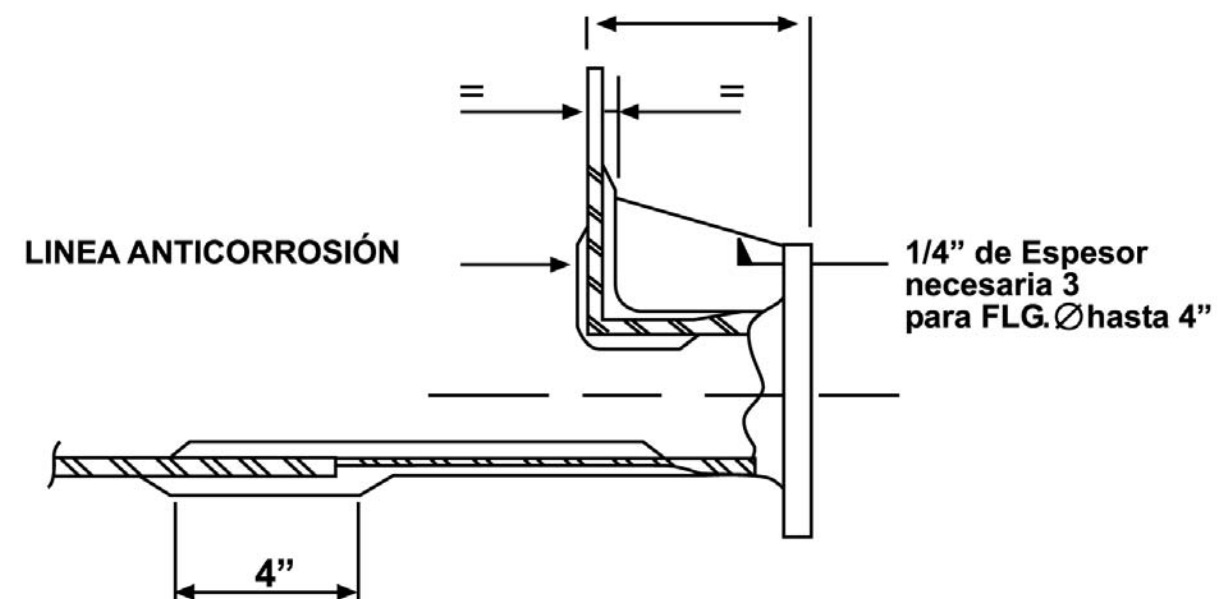

Hasta 4" = 120 mm
Sobre 4" = 150 mm

